

CLARKE®

METALWORKER



12-SPEED DRILL PRESS

MODEL NO: CDP152B

PART NO: 6505522

OPERATION & MAINTENANCE INSTRUCTIONS

UK
CE



ORIGINAL INSTRUCTIONS

GC10/24 - Rev 2

INTRODUCTION

Thank you for purchasing this CLARKE Drill Press. Before attempting to use this product, please read this manual thoroughly and follow the instructions carefully. In doing so you will ensure the safety of yourself and that of others around you, and you can look forward to your purchase giving you long and satisfactory service.

IMPORTANT

Please read all of the safety and operating instructions carefully before using this product. Please pay particular attention to all sections of these instructions that display warning symbols and notices.



WARNING: THIS SYMBOL IS USED THROUGHOUT THE INSTRUCTIONS WHENEVER THERE IS A RISK OF PERSONAL INJURY. ENSURE THAT THESE WARNINGS ARE READ AND UNDERSTOOD AT ALL TIMES.

GUARANTEE

This product is guaranteed against faulty manufacture for a period of 12 months from the date of purchase. Please keep your receipt which will be required as proof of purchase. This guarantee is invalid if the product is found to have been abused or tampered with in any way, or not used for the purpose for which it was intended.

Faulty goods should be returned to their place of purchase, no product can be returned to us without prior permission. This guarantee does not effect your statutory rights.

ENVIRONMENTAL PROTECTION

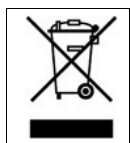

Through purchase of this product, the customer is taking on the obligation to deal with Waste Electrical/Electronic Equipment (WEEE) in accordance with the WEEE regulations in relation to the treatment, recycling & recovery and environmentally sound disposal of the WEEE. In effect, this means that this product must not be disposed of with general household waste. It must be disposed of according to the laws governing Waste Electrical and Electronic Equipment (WEEE) at a recognised disposal facility.

GENERAL SAFETY RULES



WARNING: WHEN USING ELECTRIC TOOLS, BASIC SAFETY PRECAUTIONS SHOULD ALWAYS BE FOLLOWED TO REDUCE THE RISK OF FIRE, ELECTRIC SHOCK AND PERSONAL INJURY INCLUDING THE FOLLOWING. READ ALL THESE INSTRUCTIONS BEFORE ATTEMPTING TO OPERATE THIS PRODUCT AND SAVE THESE INSTRUCTIONS FOR FUTURE REFERENCE.

GENERAL SAFETY IN THE WORKPLACE

1. Always ensure that air can circulate around the machine and that the air vents are unobstructed.
2. Always keep work area clean & tidy. Cluttered work areas and benches invite accidents.
3. Never over-reach. Keep proper footing and balance at all times.
4. Never store equipment in a wet/damp environment or expose to rain.
5. Keep other persons away. Do not let persons, especially children, not involved in the work, touch the machine or extension cable and keep them away from the work area.
6. Never operate a machine when under the influence of alcohol, drugs or medication.
7. Always ensure the workplace is well lit. Ensure that lighting is placed so that you will not be working in your own shadow.
8. Do not use power tools in the presence of flammable liquids or gasses.
9. Stay alert, watch what you are doing, use common sense and do not operate the power tool when you are tired.

CARE OF POWER TOOLS

1. Read this manual carefully. Learn the power tools applications and limitations, as well as the specific potential hazards peculiar to it.
2. Always keep guards in place and in working order. A guard or other part that is damaged should be properly repaired or replaced by your Clarke service department, unless otherwise indicated in this instruction manual.
3. Remove any adjusting keys or wrenches before starting. Form the habit of checking to ensure that keys, wrenches and tools are removed from the machine.
4. Don't force the machine and use the correct attachment. It will do the job better and safer, at the rate for which it was intended.

5. Always disconnect the machine from the power supply before carrying out any servicing or changing of accessories.
6. Before further use of the power tool, it should be carefully checked to determine that it will operate properly and perform its intended function. Check for alignment of moving parts, binding of moving parts, breakage of parts, mounting or other condition that may affect its operation.
7. Have defective switches repaired by your Clarke service department. Do not use a power tool if the switch does not turn it on and off.
8. Always check for any damage or any condition that could affect the operation of the machine. Damaged parts should be properly repaired.
9. Never remove the cover panel unless the machine is disconnected from the power supply, and never use the machine with cover panels removed.
10. Have your power tool repaired by a qualified person. This power tool complies with the relevant safety rules. Repairs should only be carried out by qualified persons using original spare parts, otherwise this may result in considerable danger to the user.
11. Never use this product for any other purpose than that described in this manual.
12. Never abuse the power cable by yanking the cable to disconnect it from the socket. Keep the cable away from heat, oil or sharp edges.
13. Guard against electric shock. Avoid body contact with earthed or grounded surfaces.
14. If the power tool should be used outdoors, use only extension cables intended for outdoor use and marked accordingly.
15. Avoid accidental starting by making sure the power switch is off before plugging in the power cable.

ADDITIONAL SAFETY RULES FOR DRILL PRESSES



CAUTION: AS WITH ALL MACHINERY, THERE ARE CERTAIN HAZARDS INVOLVED WITH THEIR OPERATION AND USE. EXERCISING RESPECT AND CAUTION WILL CONSIDERABLY LESSEN THE RISK OF PERSONAL INJURY. HOWEVER, IF NORMAL SAFETY PRECAUTIONS ARE OVERLOOKED, OR IGNORED, PERSONAL INJURY TO THE OPERATOR, OR DAMAGE TO PROPERTY MAY RESULT.

1. **IMPORTANT:** You should not operate this machine unless you are thoroughly familiar with drilling machines and drilling techniques. If there is any doubt whatsoever you should consult a qualified person.
2. Never operate the machine until it is completely assembled and you have read and understood this entire manual.

3. Always use clamps or a drill vice bolted to the table, to hold the work. It should never be held with bare hands.
4. Always shut off the power & remove drill bit before leaving the machine.
5. Always make all adjustments with the power off.
6. Always use the correct drilling speeds for the drill bit size and the type of material being drilled.
7. Never leave the drill unattended whilst it is running. Turn the machine OFF and do not leave until it has come to a complete stop.
8. Always remove and store the drill bits when you have finished work.
9. Never attempt to drill into a workpiece that does not have a flat surface unless a suitable support is used.
10. Always stop the drill before removing workpieces, work supports or swarf from the table.
11. Keep drill bits sharp and clean for best and safest performance. Follow instructions for changing accessories.
12. Adjust the table or depth stop to avoid drilling into the table surface.
13. Always be sure that the drill bit is securely locked in the chuck.
14. Never assemble or set up any work on the table while the drill is running.
15. Always ensure the table lock is tight before starting the drill.
16. Keep handles dry, clean and free from oil and grease.
17. Always keep hands and fingers away from the drill bit.



WARNING: DUST GENERATED FROM CERTAIN MATERIALS CAN BE HAZARDOUS TO YOUR HEALTH. ALWAYS OPERATE THE DRILL IN A WELL VENTILATED AREA. USE A DUST COLLECTION SYSTEM IF POSSIBLE.





WARNING: THE USE OF ANY ACCESSORY OR ATTACHMENT OTHER THAN ONE RECOMMENDED IN THIS INSTRUCTION MANUAL MAY PRESENT A RISK OF PERSONAL INJURY.

PROTECTIVE CLOTHING

1. Dress properly. Loose clothing or other jewellery may get caught in moving parts. Non-slip footwear is recommended. Wear protective hair covering to contain long hair.
2. Always wear safety glasses. (Everyday glasses are not safety glasses)
3. Wear a face mask if drilling into any material which produces dust.
4. Never wear gloves when operating rotating equipment.

SAFETY SYMBOLS

The following symbols are shown on the product or it's packaging.

	Read instruction manual before use		Wear eye protection
	Do not wear gloves		Falls within Waste Electrical Equipment (WEEE) Directive

ELECTRICAL CONNECTIONS



WARNING! READ THESE ELECTRICAL SAFETY INSTRUCTIONS THOROUGHLY BEFORE CONNECTING THE PRODUCT TO THE MAINS SUPPLY.

Before switching the product on, make sure that the voltage of your electricity supply is the same as that indicated on the rating plate. This product is designed to operate on 230VAC 50Hz. Connecting it to any other power source may cause damage.

This product may be fitted with a non-rewireable plug. If it is necessary to change the fuse in the plug, the fuse cover must be refitted. If the fuse cover becomes lost or damaged, the plug must not be used until a suitable replacement is obtained.

If the plug has to be changed because it is not suitable for your socket, or due to damage, it should be cut off and a replacement fitted, following the wiring instructions shown below. The old plug must be disposed of safely, as insertion into a mains socket could cause an electrical hazard.



WARNING! THE WIRES IN THE POWER CABLE OF THIS PRODUCT ARE COLOURED IN ACCORDANCE WITH THE FOLLOWING CODE: BLUE = NEUTRAL BROWN = LIVE YELLOW & GREEN = EARTH

If the colours of the wires in the power cable of this product do not correspond with the markings on the terminals of your plug, proceed as follows.

- The **Blue** wire must be connected to the terminal marked **N** or coloured **Black**.
- The **Brown** wire must be connected to the terminal marked **L** or coloured **Red**.
- The **Yellow and Green** wire must be connected to the terminal marked **E** or  or coloured **Green**.

Plug must be BS1363/A approved.

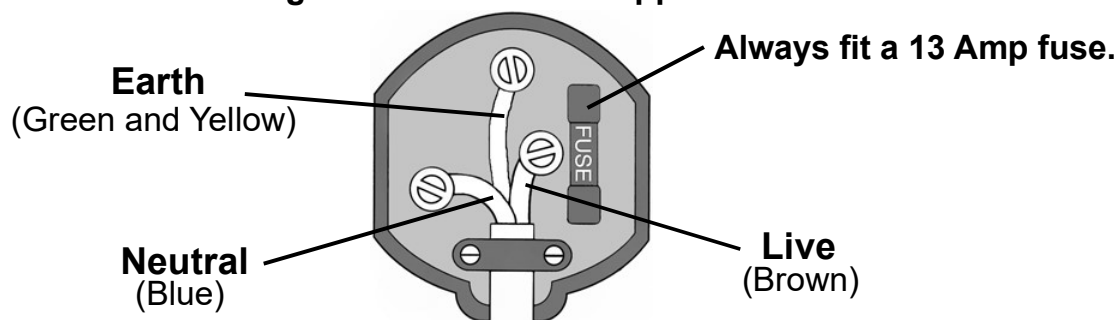

Ensure that the outer sheath of the cable is firmly held by the clamp

We strongly recommend that this machine is connected to the mains supply via a Residual Current Device (RCD)

If in any doubt, consult a qualified electrician. DO NOT attempt any repairs yourself.

PARTS INVENTORY

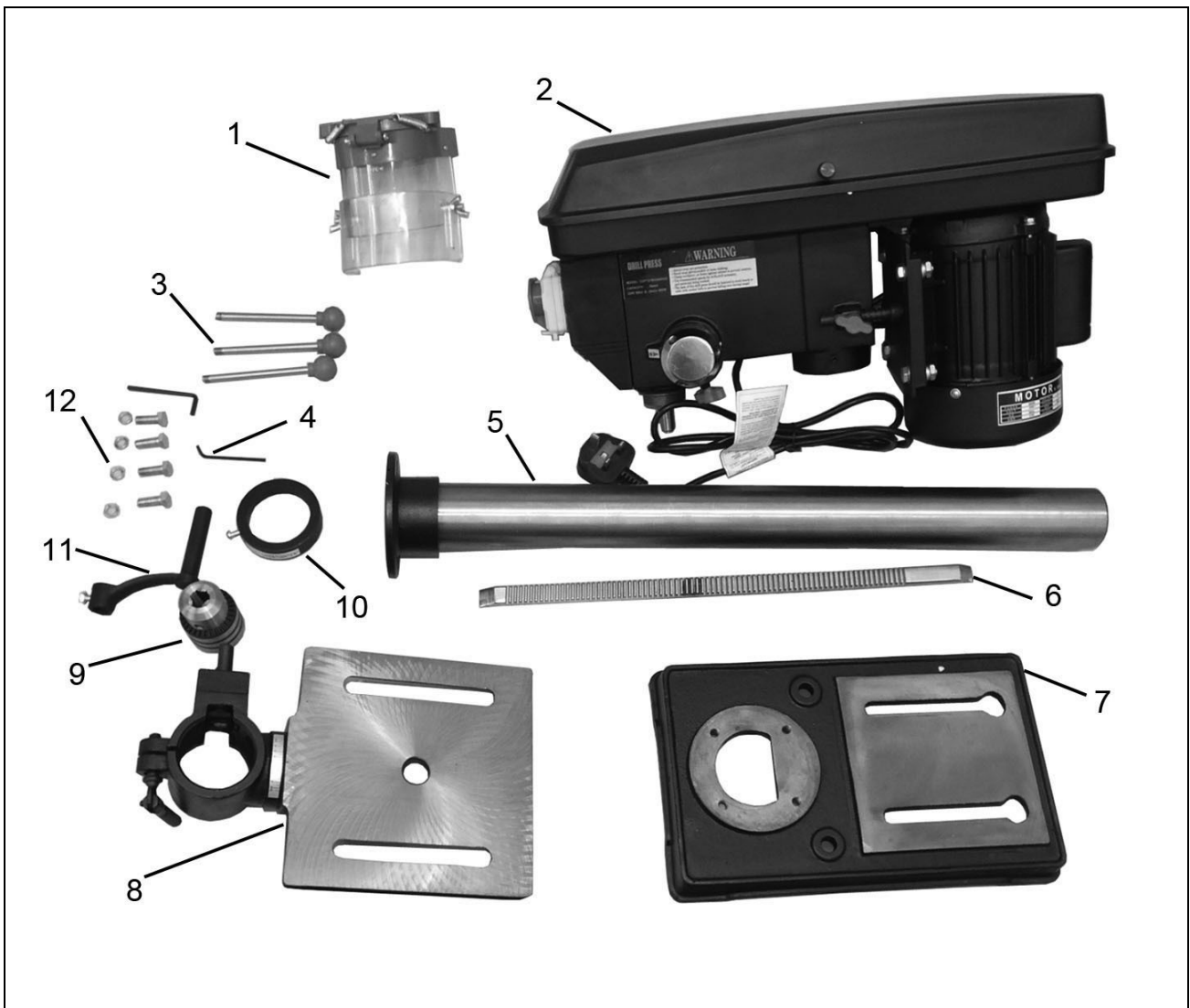

1	Chuck Guard assembly
2	Head assembly
3	Feed handles (x 3)
4	Hex Keys (3mm/4mm)
5	Column
6	Rack

7	Base
8	Table with worm drive
9	Chuck with key
10	Column collar
11	Crank handle
12	Bolts & washers

UNPACKING

The drill press is delivered with the components shown on page 8.

Check the parts against the list. Should there be any deficiencies or damage, you should contact your CLARKE dealer immediately where the product was originally purchased. Do not discard the packaging until the machine is assembled. The packaging consists of cardboard and appropriately marked materials which can be sent to a re-cycling facility.

To protect the machine parts from moisture, a protective coating of light machine oil will have been applied to the outside surfaces. Remove any excess with a paper towel.

Take care when lifting the head assembly, considering its weight.

ASSEMBLY

Before use, the machine must be mounted and securely bolted to a strong, heavy workbench, of sufficient height that you will be standing upright when working.

Ensure the work place is adequately lit, and that you will not be working in your own shadow.

COLUMN TO BASE

1. Bolt the column to the base with the four bolts and washers provided.

NOTE: Ideally, the base with column attached, should be firmly bolted to the workbench, prior to the assembly of other components.

TABLE TO COLUMN

1. Push the crank onto the worm drive spigot protruding from the gear housing. Tighten the crank set screw onto the flat side of the spigot using a hex key supplied.

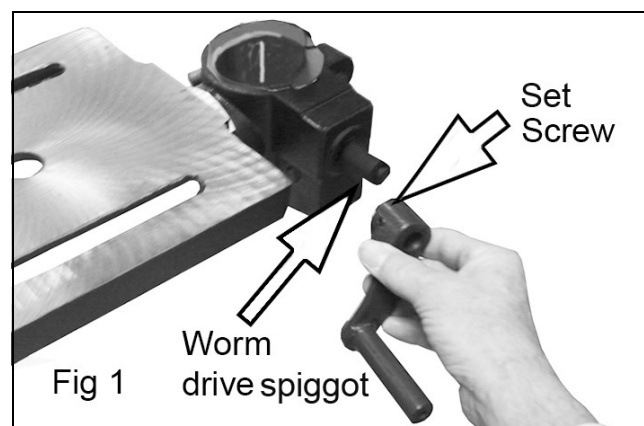

2. Position the rack in the slot in the table support, so that the rack teeth engage with the worm gear. Position the centre of the rack close to the worm gear as shown in Fig 2, with the long, smooth end uppermost.
3. Holding it in this position, slide the table support, complete with the rack, onto the column.

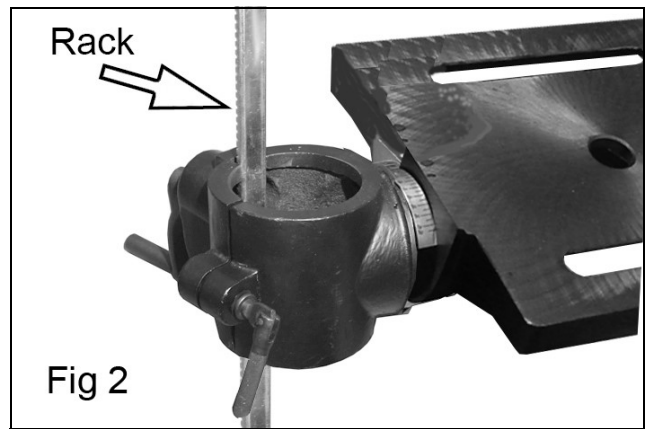

4. Lower the assembly so that the lower end of the rack sits fully into the recess at the base of the column support as in Fig 3.

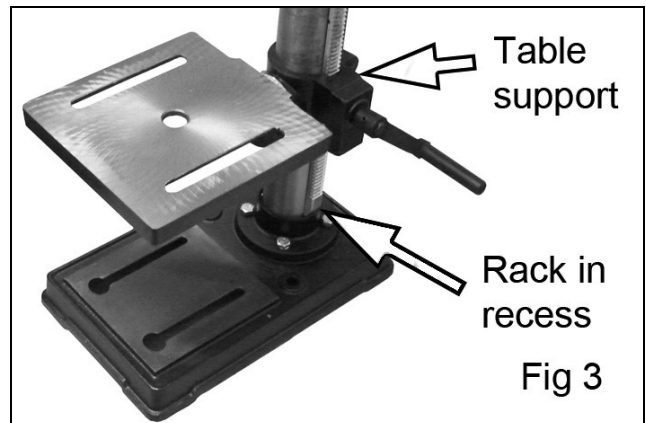

5. Fit the collar onto the column, with the recess facing downwards to hold the top of the rack in place.
6. With the rack sitting snugly in the recesses, top and bottom, tighten the collar set screw with a hex key, as shown in Fig 4. Do not overtighten.
7. Ensure there is sufficient clearance to allow the complete table assembly to move around the column. If necessary, reposition the collar to achieve good movement.
8. Check that the table moves smoothly from top to bottom of the rack by turning the crank handle.



HEAD TO COLUMN

NOTE: It may be necessary to unscrew the set-screws (shown in fig.4) to ensure they do not protrude internally and foul the column, as this would prevent the head from sliding fully into position.

1. With the help of an assistant, lift up the head assembly and locate it on the column, ensuring it slides fully home.
2. Align the head assembly with the machine base and tighten the head locking set screws shown in Fig 5 using the hex key supplied.
3. Take the three feed handles and screw them firmly into the hub of the feed shaft as shown in Fig.6.

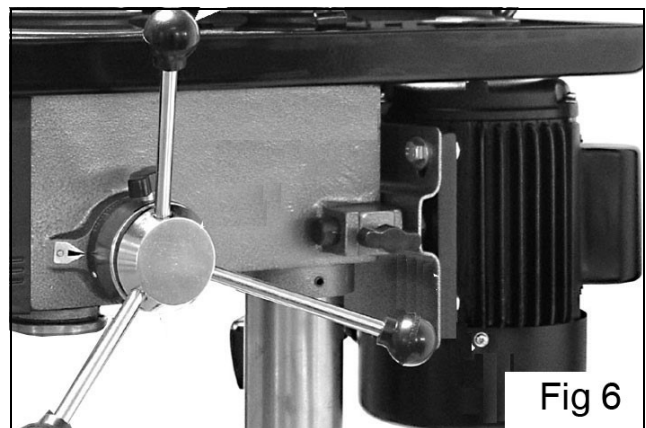

CHUCK GUARD ASSEMBLY

This task should be carried out before the chuck is installed.

1. Slide the chuck guard over the quill shaft and nip up the pinch bolt, temporarily, with the pinch bolt facing the front (see fig 7).
 - This will make fitting the chuck easier. Ensure the quill shaft/drive spindle is at the top of it's travel.

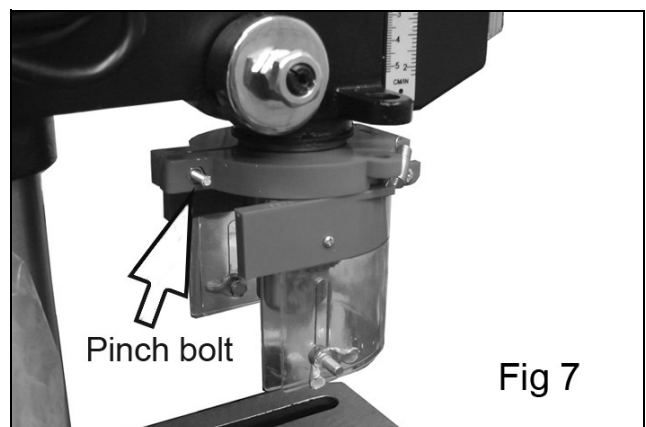

INSTALLING THE CHUCK

1. Open the jaws of the chuck as far as possible using the chuck key supplied. Ensure the tapered hole in the chuck is clean and fit the chuck onto the tapered end of the drive spindle with a firm pressure.
2. Tap the chuck firmly with a rubber mallet until the tapered end of the chuck engages with the drive spindle.



CAUTION: IF A RUBBER Mallet IS NOT AVAILABLE, PROTECT THE CHUCK WITH A BLOCK OF SCRAP TIMBER BEFORE STRIKING WITH A HAMMER. ALWAYS ENSURE THE CHUCK JAWS ARE FULLY OPEN BEFORE STRIKING THE CHUCK.

3. Slacken the chuck guard pinch bolt and turn the chuck guard so the pinch bolt is at the rear before re-tightening.

BELT TENSIONING

1. Open the cover and slacken the belt tension locking knob.
2. Lever the motor/bracket, away from the head as shown in Fig 9, so that tension is applied to the belts.
 - Tension is correct when the belt deflects by approx 10 mm at the centre of its span when using reasonable thumb pressure.
3. Lock the motor in this position by tightening the locking knob.

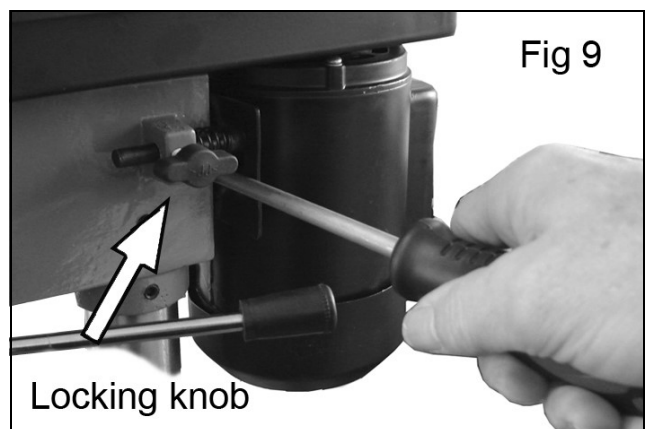

NOTE: If the belt slips whilst drilling, re-set the belt tension.

CHECKING THE OPERATION OF THE MICROSWITCH

When closing the cover, check the operation of the micro-switch.

It is important that it operates as soon as the cover is opened in order to prevent the machine from operating. If necessary, adjust the position of the actuating tab inside the cover to ensure correct operation.

SETTINGS AND ADJUSTMENTS

TABLE

The table may be raised, lowered or swiveled around the column by slackening the table support locking handle shown in Fig 10, and adjusting the table position accordingly and re-tightening the locking handle.



It may also be tilted by loosening the bolt which secures the table to its mounting, tilting the table to the required position and re-tightening the bolt shown in Fig 11.

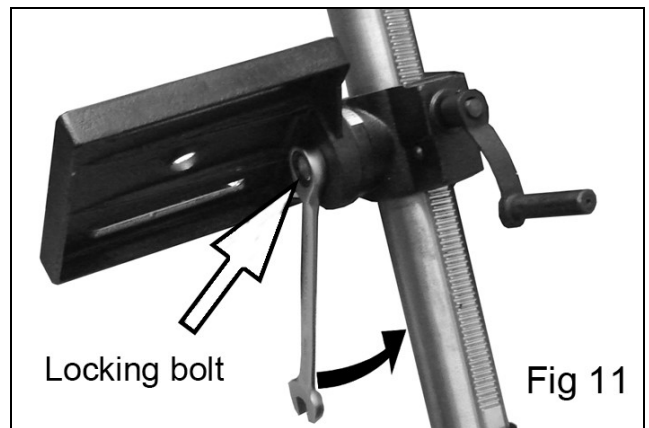

A bevel scale is provided on the table mounting, (measured in degrees), to assist in setting the required angle. However, for greater accuracy the use of a protractor is recommended.

For all normal operations, the table should be set to 0°.

To check to ensure the drill is perpendicular to the table, install a large drill bit in the chuck, place a set-square on the table, and bring it up to the drill. Adjust the table if necessary, so that it is perfectly level.

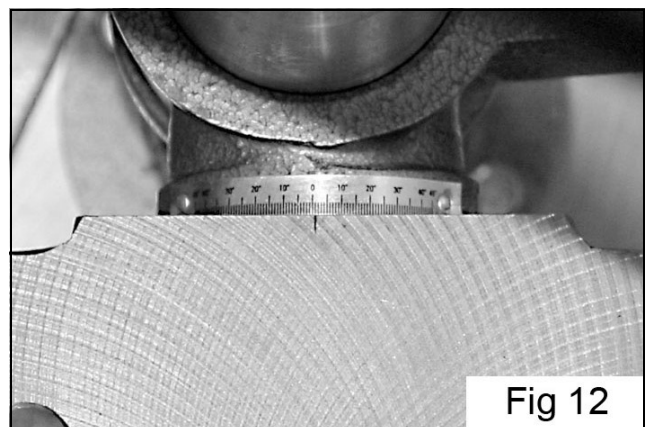

SPINDLE DEPTH STOP

Located on the spindle feed shaft is a depth stop collar, carrying a graduated scale (A, in Fig.13). The collar can rotate around the shaft and may be locked in place by the locking screw B.

The graduations represent the hole depth in mm.

TO SET A DRILLING DEPTH:

1. With the drill bit installed and tightened securely, lower it with the power off, so that the bit lightly touches the workpiece.
2. Hold in that position whilst slackening the locking knob (B) and rotating the scale (A) ANTICLOCKWISE until it stops with the zero mark opposite the pointer (C).
3. Tighten the knob and allow the mechanism to return to its starting position.
4. Note the reading on the scale. This will be the measured distance of the drill bit from the workpiece.
5. Decide on the depth of hole required and add this (in mm), to the value on the scale. Re-tighten the knob.
 - e.g. If the drill was 27 mm from the workpiece and you require a 10 mm deep hole, slacken the knob and turn the scale to read 37 mm.

The drill is now set to drill holes to your desired depth. Providing your workpiece is level and flat, you may drill a series of holes, each to the same depth, quickly and accurately.

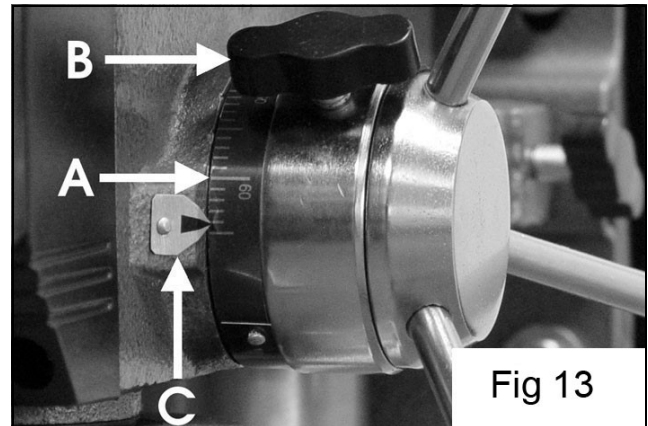

Fig 13

CHANGING THE SPEED

Before changing the speeds, ensure the machine is switched OFF, and disconnected from the power supply.

1. Open the pulley cover.
2. Slacken off the belt tension locking knob to relieve tension on the drive belts.
3. Refer to the chart inside the pulley cover or the table on page15 and position the belts on the pulleys according to the drilling speed required.

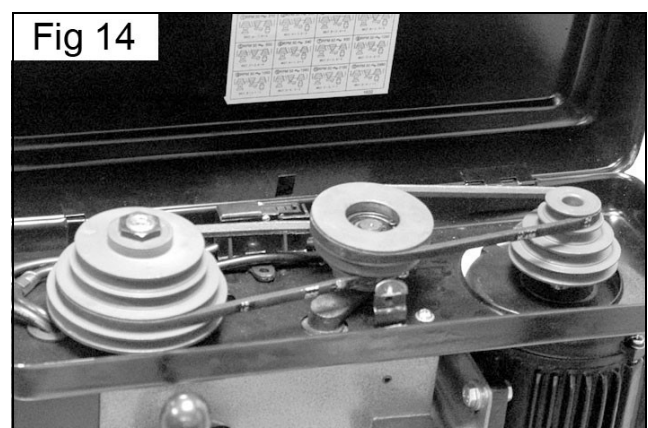

Fig 14

4. When the belt has been correctly positioned, re-tension by levering the motor away from the head until the belt deflects by approx 10 mm at its centre when using reasonable thumb pressure.
5. Lock the motor in this position with the belt tension locking knob.

DRILL OPERATING SPEEDS

The table below gives the belt arrangement for given drilling speeds.

A similar chart is also located on the inside of the pulley cover.

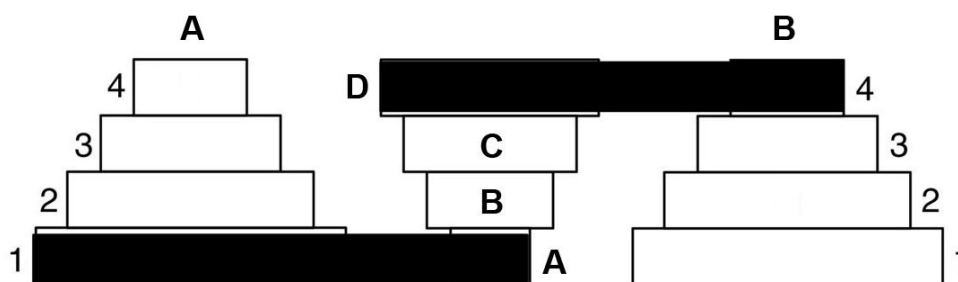

The diagram shows the belts fitted to step 4 of the spindle pulley and step 1 of the motor pulley, giving a speed of 300rpm.

	SPINDLE PULLEY A / CENTRE	MOTOR PULLEY B / CENTRE/	DRILL SPEED RPM
1	1-A	D-4	300
2	2-B	D-4	440
3	1-A	C-3	460
4	3-C	D-4	570
5	1-A	B-2	650
6	2-B	C-3	680

	SPINDLE PULLEY A / CENTRE	MOTOR PULLEY B / CENTRE	DRILL SPEED RPM
7	4-D	C-3	1220
8	3-C	B-2	1250
9	2-B	A-1	1430
10	4-D	B-2	1750
11	3-C	A-1	1840
12	4-D	A-1	2550

OPERATION

1. Insert the drill bit into the jaws of the chuck by approx 1". Before tightening the chuck, ensure that the drill bit is centred within the jaws.
2. Ensure the table height and position is set, so that drill travel is sufficient for the job in hand.
3. Ensure the work is securely clamped or held in a drill vice, bolted to the work table. Never hold it with bare hands. Personal injury may be caused if the workpiece is whipped out of the operators hand and damage incurred to anything it strikes.
 - If the workpiece is an irregular shape and cannot be laid flat on the table, it should be securely blocked and clamped in position.
 - Any movement results not only in a rough hole, but also increases drill bit breakage.
4. For small workpieces that cannot be clamped to the table, use a drill vice. The vice must be clamped or bolted to the table.
5. When drilling completely through wood, always position a piece of scrap wood between the workpiece and the table to prevent splintering on the underside of the workpiece as the drill breaks through. The scrap piece of wood must make contact with the left side of the column as shown in Fig 15 to prevent it moving.
6. In addition, set the depth of drill travel so that the drill bit cannot come into contact with the table, or align the table so that the hole in its centre is in line with the drill bit.
7. Form the habit of checking to see that the chuck key is removed from the chuck before turning it on.



8. When completely satisfied that the setup is correct, lower the chuck guard into position and switch the machine ON.

- Switch on by pushing the 'I' button.
- To switch OFF, push the 'O' button, see Fig 16.

9. During use, the emergency stop button will drop down over the other buttons. To stop the machine instantly, just strike the red button. To re-start, unclip and lift the hinged stop button/cover to access the regular start/stop buttons.

NOTE: As a safety feature, the ON/OFF switch is a 'No Volt Release' type. Therefore, if the power is interrupted whilst the machine is switched ON, it will not automatically start when power is restored.

10. Slowly turn the feed handles to bring the drill bit down towards the table and into your workpiece. Ease the drill bit back up to clear swarf away as required. After drilling, release the feed handles slowly to return the machine to its starting position.

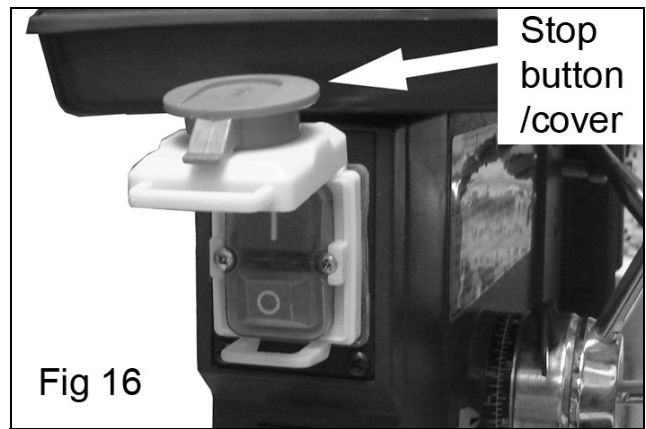

DRILLING SPEEDS

Factors which determine the best speed to use are:

- Type of material being worked
- Size of hole
- Quality of cut desired
- Type of drill bit

Generally, the smaller the drill bit, the greater the required speed. In soft material, the speed should be higher than for hard metals.

As a guide, the drill speed for a given drill bit size is according to the table below:

Speed Range	(rpm)	2180 -2580	1580	1290 -1350	830	500 - 540	320- 420	210- 280
Wood	inches mm	1/4 6.4	3/8 9.5	5/8 16	- -	- -	- -	- -
Zinc Diecast	inches mm	3/16 4.8	1/4 6.4	3/8 9.5	1/2 12.5	5/8 16	- -	- -
Alum & Brass	inches mm	1/8 3.2	3/16 4.8	3/8 9.5	1/2 12.5	11/16 17.5	- -	- -
Plastic	inches mm	1/8 3.2	3/16 4.8	5/16 7.9	7/16 11	1/2 12.5	5/8 16	- -
Cast Iron & Bronze	inches mm	3/32 2.4	1/8 3.2	1/4 6.4	11/32 8.75	1/2 12.5	5/8 16	- -
Mild Steel & Malleable	inches mm	1/16 1.6	3/32 2.4	5/32 4	1/4 6.4	3/8 9.5	1/2 12.5	- -
Cast Steel & Med Carbon	inches mm	3/64 1.2	1/16 1.6	1/8 3.2	3/16 4.8	5/16 7.9	7/16 11	9/16 14.5
Stainless & Tool Steel	inches mm	1/32 0.8	3/64 1.2	1/16 1.6	1/8 3.2	1/4 6.4	3/8 9.5	1/2 12.5

DRILL VICES

In order to secure the workpiece to the table, a complete range of drill vices, cross vices and clamps is available from your Clarke dealer.

MAINTENANCE

For maximum performance, it is essential that the machine is properly maintained. Always inspect it before use. Any damage should be repaired, and faults rectified. Always unplug from the power supply before carrying out any adjustment, servicing or maintenance.

Please refer to the Troubleshooting chart on page 20. If you are unable to rectify any faults, please contact your local dealer or Clarke International for assistance.

MONTHLY (IF IN CONSTANT USE)

1. Check the tightness of mounting bolts and head and column securing set screws.
2. Check the drive belts for wear, and replace if frayed or damaged.
3. Use compressed air or a vacuum cleaner, to remove any dust that may have accumulated in the motor vents.
4. Apply a thin coat of wax paste or light oil to the table and column for lubrication and to help prevent corrosion.

If the mains lead is damaged in any way it should be replaced immediately.

LUBRICATION

All bearings are packed with grease at the factory and require no further lubrication.

Occasionally lubricate the quill shaft assembly with light oil if required.

AFTER USE

Remove all swarf from the machine and thoroughly clean all surfaces.

Components should be kept dry, with machined surfaces lightly oiled.

Always remove drill bits and store in a safe place.

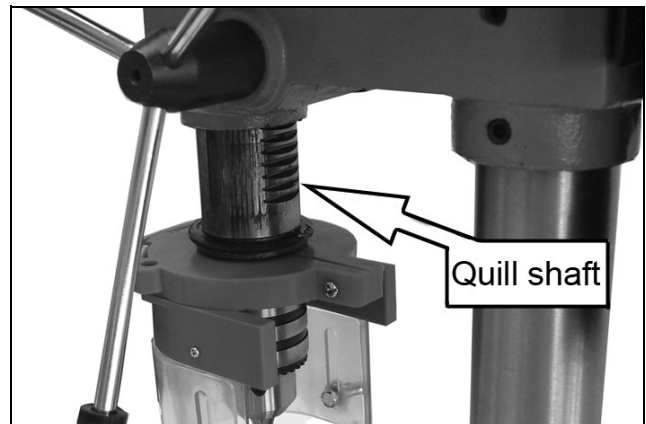

TROUBLESHOOTING

PROBLEM	PROBABLE CAUSE	REMEDY
Noisy operation (under load)	<ul style="list-style-type: none"> a. Incorrect belt tension. b. Dry spindle. c. Loose pulley. d. Loose belt. e. Worn bearing. 	<ul style="list-style-type: none"> a. Adjust tension. b. Remove spindle and quill assembly and lubricate. c. Tighten pulley. d. Adjust belt tension. e. Replace bearing.
Excessive drill wobble.	<ul style="list-style-type: none"> a. Loose chuck. b. Worn spindle or bearing. c. Worn chuck. d. Bent drill bit. 	<ul style="list-style-type: none"> a. Tighten by pressing chuck down on to a block of wood against the table. b. Replace spindle shaft or bearing. c. Replace chuck. d. Renew drill bit.
Motor won't start.	<ul style="list-style-type: none"> a. Power supply. b. Motor connection. c. NVR switch connection faulty. d. Faulty switch. e. Motor windings burned. f. Pulley cover not closed. g. Micro switch on cover not operating. 	<ul style="list-style-type: none"> a. Check power cord/fuse. b. Check motor connections. c. Check switch connections. d. Replace switch. e. Replace motor. f. Close pulley cover. g. Check operation of micro switch, and renew/adjust as necessary. (Consult your Clarke dealer for advice).
Drill binds in work-piece.	<ul style="list-style-type: none"> a. Excessive feed pressure. b. Loose belt. c. Loose drill. d. Incorrect bit speed. e. Drill angles incorrect for type of material. 	<ul style="list-style-type: none"> a. Apply less pressure. b. Check belt tension. c. Tighten drill with key. e. Refer to Cutting Speed chart and adjust drill speed accordingly. e. Consult a technical manual dealing with materials, drills and cutting angles, and sharpen drill accordingly.

Drill bit burns or smokes.	<ul style="list-style-type: none"> a. Incorrect speed. b. Swarf is not discharging c. Dull drill or not proper clearance for material. d. Needs coolant. e. Excessive feed pressure 	<ul style="list-style-type: none"> a. Refer to Cutting Speed chart & adjust drill speed accordingly. b. Clean drill. c. Check sharpness & taper. d. Use coolant whilst drilling. e. Apply less pressure.
Table difficult to raise.	<ul style="list-style-type: none"> a. Needs lubrication. b. Table lock tightened. 	<ul style="list-style-type: none"> a. Lubricate with light oil. b. Loosen clamp.

SUITABLE ACCESSORIES

Drill Press Vices available from your Clarke dealer include:

Model	Jaw Width	Max Opening	Depth	Weight	Part No
CDV30C	76 mm	78 mm	19 mm	2 kg	6504019
CDV40C	102 mm	97 mm	28 mm	3 kg	6504020
CDV50C	127 mm	125 mm	37 mm	5 kg	6504021
CDV60C	152 mm	150 mm	38 mm	6 kg	6504022



Table Clamps available from your Clarke dealer include:

Model	Size	Max Clamp Height	Part No
CVC6	152 mm	38 mm	6501920
CVC9	229 mm	95 mm	6501925

SPECIFICATION

Overall Height	830 mm
Table Dimensions	203 x 195 mm
Base Dimensions	207 x 338 mm
Chuck Capacity	3-16 mm
Max Chuck to Table Distance	355 mm
Max Chuck to Base Distance	460 mm
Spindle Speed Range	300-2550 rpm
No of Speeds	12
Spindle Taper	B16
Max Spindle Travel	60 mm
Product Weight	27.6 kg
Motor Supply	230Vac/50Hz/1ph
Power Rating	450 W
Current Rating	2.0 A
Motor Speed	1420 rpm
IP Rating	20
Duty Cycle	S2 30 min
Sound Pressure Level	62 dB LpA
Sound Power Level	75 dB LwA
Uncertainty Factor (K)	3

COMPONENT PARTS

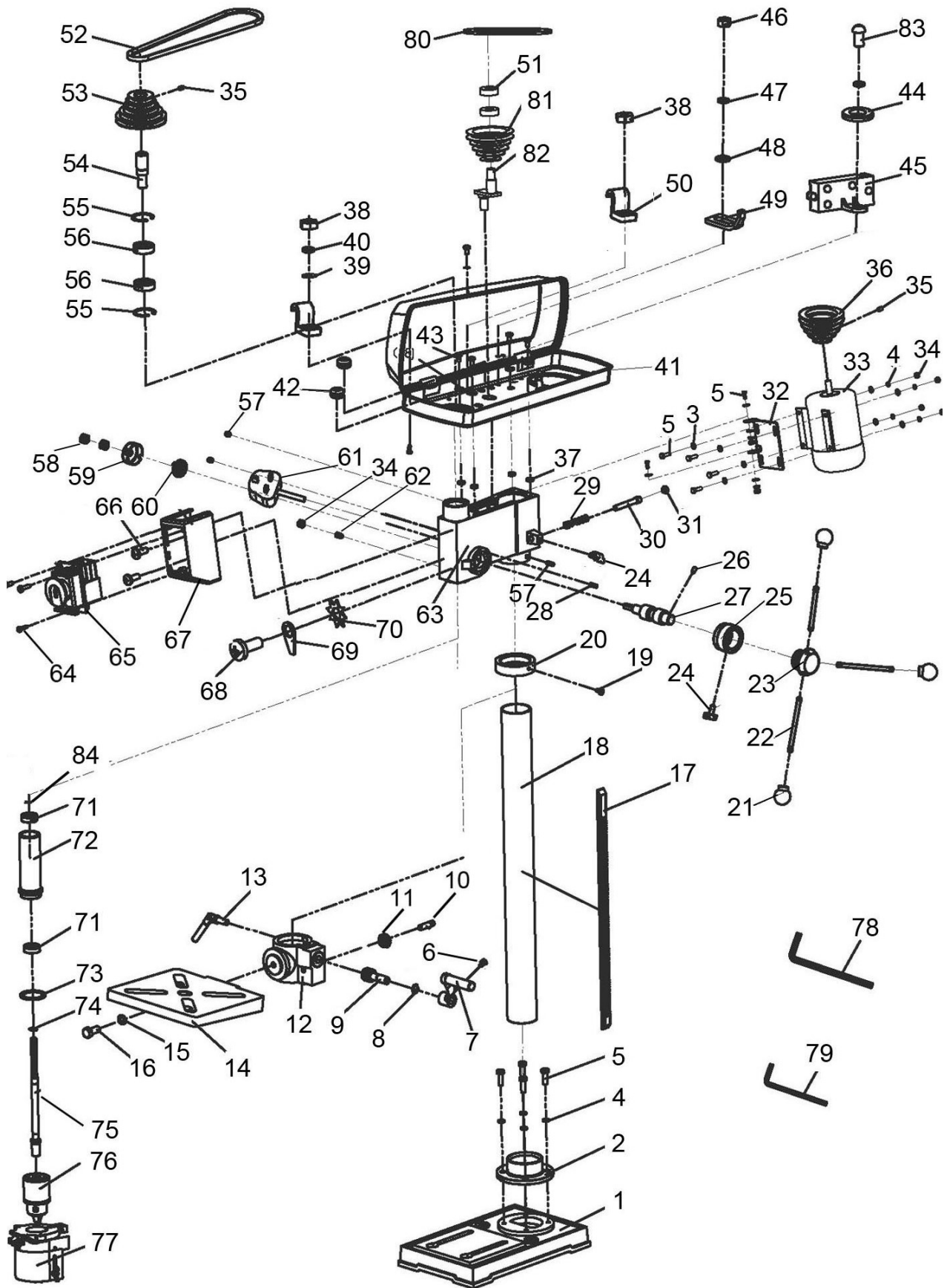

COMPONENT PARTS

No	Description
1	Base
2	Column Flange
3	Flat Washer
4	Spring Washer
5	Hex Bolt M8x25
6	Hex Bolt M6x12
7	Crank Handle
8	Circlip 14mm
9	Worm
10	Worm Pin
11	Worm Gear
12	Table Support
13	Locking Handle
14	Working Table
15	Spring Washer
16	Hex Bolt M12x25
17	Rack
18	Column
19	Cross Pan Head Screw
20	Rack Collar
21	Handle Tip
22	Handle
23	Handle Seat
24	Locking Handle Knob
25	Dial Scale
26	Roll Pin
27	Gear Shaft
28	Roll Pin
29	Motor Spring
30	Motor Push Rod

No	Description
31	Washer
32	Motor Connection Plate
33	Motor
34	Nut
35	Hex Socket Set Screw
36	Motor Pulley
37	Damping Washer
38	Nut
39	Flat Washer
40	Spring Washer
41	Pulley Cover
42	Protective Ring
43	Cross Pad Head Screw
44	Large Flat Washer
45	Micro Switch
46	Nut
47	Spring Washer
48	Flat Washer
49	Micro Pressure Claw
50	Cable Clamp
51	Bearing
52	Drive Belt
53	Spindle Pulley
54	Keyed Spindle
55	Circlip
56	Bearing
57	Hex Socket Set screw
58	Nut
59	Spring Cover
60	Spring

61	Plug and Cable
62	Screw M8x15
63	Housing
64	Cross Head Self-tapping screw
65	Switch
66	Cross Head screw
67	Switch Box
68	Cross Head screw
69	Earth Connection
70	Tooth Lock Washer
71	Bearing
72	Spindle Socket

73	Washer
74	Circlip 12mm
75	Main Spindle
76	Chuck
77	Chuck Guard
78	Hex Wrench
79	Hex Wrench
80	Drive Belt
81	Middle Pulley
82	Eccentric Shaft
83	Cross Pan Head Screw
84	Circlip 12mm

DECLARATION OF CONFORMITY



DECLARATION OF CONFORMITY

This is an important document and should be retained.

We hereby declare that this product(s) complies with the following statutory requirement(s):

- Electromagnetic Compatibility Regulations 2016
- Supply of Machinery (Safety) Regulations 2008
- The Restriction of the Use of Certain Hazardous Substances in Electrical and Electronic Equipment Regulations 2012

The following standards have been applied to the product(s):

- EN 55014-1:2017, EN 55014-2:2015, EN 61000-3-2:2014, EN 61000-3-3:2013,
- EN 60204-1:2018, EN 12717:2001/A1:2008, IEC 62321-3-1:2013, IEC 62321-4:2013+AMD1:2017C5V,
- IEC 62321-5:2013, IEC 62321-6:2015, IEC 62321-7-1:2015, IEC 62321-7-2:2017, IEC 62321-8:2017,
- ISO 17075:2007.

The technical documentation required to demonstrate that the product(s) meet(s) the requirement(s) of the aforementioned legislation has been compiled and is available for inspection by the relevant enforcement authorities.

The UKCA mark was first applied in: 2022

Product Description: Bench Drill Presses
Model number(s): CDP152B, CDP202B, CDP302B
Serial / batch Number: N/A
Date of issue: 10/03/2022

Signed:

J.A. Clarke
Director

CDP152B UKCA Clarke DOC 03.1022

Page 1 of 1



DECLARATION OF CONFORMITY

This is an important document and should be retained.

We hereby declare that this product(s) complies with the following directive(s):

- 2004/108/EC Electromagnetic Compatibility Directive.
- 2006/42/EC Machinery Directive.
- 2011/65/EU Restriction of Hazardous substances.

The following standards have been applied to the product(s):

- EN 55014-1:2017, EN 55014-2:2015, EN 61000-3-2:2014, EN 61000-3-3:2013,
- EN 60204-1:2018, EN 12717:2001/A1:2008, IEC 62321-3-1:2013, IEC 62321-4:2013+AMD1:2017C5V,
- IEC 62321-5:2013, IEC 62321-6:2015, IEC 62321-7-1:2015, IEC 62321-7-2:2017, IEC 62321-8:2017,
- ISO 17075:2007.

The technical documentation required to demonstrate that the product(s) meet(s) the requirement(s) of the aforementioned directive(s) has been compiled and is available for inspection by the relevant enforcement authorities.

The CE mark was first applied in: 2011

Product Description: Bench Drill Presses
Model number(s): CDP152B, CDP202B, CDP302B
Serial / batch Number: N/A
Date of issue: 10/03/2022

Signed:

J.A. Clarke
Director

CDP152B CE Clarke DOC 03.1022

Page 1 of 1

A SELECTION FROM THE VAST RANGE OF

Clarke®

QUALITY PRODUCTS



AIR COMPRESSORS
From DIY to industrial, Plus air tools, spray guns and accessories.

GENERATORS
Prime duty or emergency standby for business, home and leisure.

POWER WASHERS
Hot and cold, electric and engine driven - we have what you need

WELDERS
Mig, Arc, Tig and Spot. From DIY to auto/industrial.

METALWORKING
Drills, grinders and saws for DIY and professional use.

WOODWORKING
Saws, sanders, lathes, mortisers and dust extraction.

HYDRAULICS
Cranes, body repair kits, transmission jacks for all types of workshop use.

WATER PUMPS
Submersible, electric and engine driven for DIY, agriculture and industry.

POWERTOOLS
Angle grinders, cordless drill sets, saws and sanders.

STARTERS/CHARGERS
All sizes for car and commercial use.



PARTS & SERVICE: 0208 988 7400

Parts Enquiries
Parts@clarkeinternational.com

Servicing & Technical Enquiries
Service@clarkeinternational.com

SALES: UK 01992 565333 or Export 00 44 (0)1992 565335

Clarke® INTERNATIONAL Hemnall Street, Epping, Essex CM16 4LG
www.clarkeinternational.com